

THE NUBIAN POTTERY FROM THE PALACE DISTRICT OF AVARIS AT ^cEZBET HELMI, AREAS H/III AND H/VI

PART III: THE “CLASSIC” KERMA POTTERY FROM THE SECOND INTERMEDIATE PERIOD AND THE 18th DYNASTY

By Perla Fuscaldo

INTRODUCTION

The pottery analysis presented here is related to some unpublished Kerma sherds found in Tell el-Dab^ca/Avaris at ^cEzbet Helmi, areas H/III and H/VI,¹ during the excavations carried out by the Austrian Archaeological Institute in Cairo under the direction of Manfred Bietak between 1998 and 2005.²

Thirty-seven Kerma sherds were recovered in both areas. Two fragments (*Nos. 1* and *2*) appeared in pottery contexts of the Second Intermediate Period, the relative strata f and e/2, dated in the late Hyksos Period (= Phase D/2).³ Thirty-one were found in strata of the 18th Dynasty, namely in the early phase of this period (stratum e/1 = Phase D/1; *Nos. 3* to *6*), in the early to the early–middle 18th Dynasty (stratum e/1–d = Phase D/1–C/3; *Nos. 7* and *8*), and in the early–middle 18th Dynasty (strata d, d–c and c = Phases C/3, C/3–C/2 and C/2 respectively; *Nos. 9* to *33*).⁴

One sherd (*No. 34*) comes from a context of the late 18th Dynasty (stratum b/2 = Phase B/3, Tutankhamun and Horemheb), and three (*Nos. 35* to *37*) were found in strata that can only be dated between the late 18th Dynasty and recent times.⁵

All these ceramics, which are described in the *Catalogue* below, belong to the “Classic” Kerma Period.

COMMENTARY

This Kerma pottery is very fragmentary and comprises mostly body sherds; only four rims have been preserved. They belong to two wares, the black-topped red polished ware and the general household ware. The black-topped red polished ware is a fine ware represented by beakers and bowls, made of Nile B₂, with a groundmass of fine to medium quality, and quite thin walls; the exterior surface is red-slipped and the interior black; both surfaces are polished with high to medium

¹ On other Kerma sherds from the same areas: P. FUSCALDO, *The Nubian Pottery from the Palace District of Avaris at ^cEzbet Helmi, Areas H/III and H/VI. Part I: The “Classic” Kerma Pottery from the 18th Dynasty*, *Ä&L* 12 (2002) 167–189; Part II: *The “Classic” Kerma Pottery from the Second Intermediate Period and the 18th Dynasty*, *Ä&L* 14 (2004) 111–119. On the Kerma pottery and the Kerma people in Egypt, see the bibliography mentioned in these articles. The Kerma sherds from ^cEzbet Helmi, areas H/I, H/II and H/IV, were published by I. HEIN, *Kerma in Avaris*, in: *Begegnungen, Festschrift für Endesfelder, Priese, Reinecke und Wenig*, Leipzig 2001, 199–212; other material, recovered during 2005 in some squares of H/VI, is being studied by B. Bader.

² On the preliminary reports of the excavations see: M. BIETAK, J. DORNER, and P. JÁNOSI, *Ausgrabungen in dem Palastbezirk von Avaris. Vorbericht Tell-el Dab^ca/^cEzbet Helmi 1993–2000, mit einem Beitrag von A. von den Driesch und Joris Peters*, *Ä&L* 11 (2001) 11 and 27–100;

and M. BIETAK and I. FORSTNER-MÜLLER, *Ausgrabung eines Palastbezirkes der Tuthmosidenzeit bei ^cEzbet Helmi/Tell el-Dab^ca, Vorbericht für Herbst 2004 und Frühjahr 2005*, *Ä&L* 15 (2005) 65–100.

³ The last part of the 15th Dynasty and the beginning of the occupation of Avaris by Ahmose.

⁴ On the pottery typology of Phases D/1 to C/3, see P. FUSCALDO, *Tell el-Dab^ca: Some Remarks on the Pottery from ^cEzbet Helmi (Areas H/III and H/VI, strata e/1 and d)*, 301–316, in: M. BIETAK and E. CZERNY (eds.), *The Synchronisation of Civilisations in the Eastern Mediterranean in the Second Millennium B.C., III. Proceedings of the SCIEM 2000–2nd EuroConference, Vienna 28th of May–1st of June 2003*, CChEM 9, Vienna 2007. The pottery contexts from H/III and H/VI (stratum c) are being studied by David Aston.

⁵ For the distribution of Kerma sherds by strata see below, *Addenda, I*.

lustre; the rim zone is black, with some parts very dark grey and grey to pinkish grey. The general household ware includes bowls and cooking pots. They have a black-topped rim and the surface covered with a red polished slip, or the surface decorated with an incised or impressed pattern; the interior is generally black and polished. The bowls are made of Nile B₂ or Nile E₁, seldom of Nile C; the fabrics used for the cooking pots are Nile B₂ (sandy), Nile E₁ and, above all, Nile E₃. The shaping technique is always hand made.

The two sherds found in contexts of the late Hyksos Period belong to *beakers*, made of a fine Nile B₂ fabric.⁶ *No. 1* (Inv. No. 9071W, Fig. 1:a)⁷ is a fragment of the black-topped zone near the rim, polished with high lustre. *No. 2* (Inv. No. 9071K, Fig. 1:b)⁸ is a fragment from the middle part of the body, covered with a reddish brown polished slip. The interior of both sherds is black and polished with high lustre.

The Kerma shapes from the 18th Dynasty contexts are beakers, bowls and cooking pots. The *beakers*, *Nos. 3 to 5, 9, 23 to 27*, are made of Nile B₂, with a groundmass of fine to medium quality. The wall thickness is between 0.25 and 0.40 cm. The fragments belong mostly to the middle part of the body, with a red slip (10R 5/6 to 2.5YR 5/8).⁹ But some fragments are from the upper part of the body: they preserve the black-topped zone,¹⁰ 7.5YR 2.5/1, polished with high lustre outside and inside, or the transitional one between the red-slipped area and the black rim. In this case, the decoration includes a matte grey (5YR 6/1 and 5/1)¹¹ or a pinkish grey (5YR 7/2) to grey (Chart 1 for gley, N5/1) zone, with high lustre.¹² The most complete decoration is a black-topped zone (7.5YR 2.5/1 black on the top and

3/1 very dark grey below) and a transitional one in dusky red (10R 3/4) and bluish grey (5/1–6/1, Chart 2 for gley), with high lustre outside,¹³ or matte black (5YR 2.5/1), very dark grey (5YR 3/1), grey (Chart 1 for gley N6) and weak red (10R 4/3) zones.¹⁴ The interior of all the beakers is black and polished with high lustre.

Seven sherds are from *bowls*,¹⁵ six made of Nile B₂ and one of Nile C₁,¹⁶ a fabric tempered with small amounts of chaff, and a groundmass of medium quality. The wall thickness is between 0.40 and 0.70 cm. Two fragments preserve the black-topped area, *No. 10*,¹⁷ a rim sherd from a convex-sided bowl, 16 cm in diameter, 0.50 cm of wall thickness and 3 cm high, with a very dark grey (7.5YR 3/1) rim band on the weak red slip, and *No. 11*,¹⁸ a body sherd with a black-topped zone (5YR 4/1 dark grey and 2.5/1 black), uneven inside. The others, *Nos. 6 and 7*,¹⁹ *18 to 20*,²⁰ are body sherds from the red-slipped zone. In all of them the interior is black and polished with low to high lustre. *Nos. 19 and 20* preserve inside polishing marks. 34-678

Fifteen sherds, from bowls²¹ and cooking pots,²² belong to the category of general household ware, with a red-slipped polished exterior surface and black-topped rim, or with an incised or impressed decoration. Although the shape and the surface treatment are similar with both bowls and cooking pots, the function can be specified by the fabric: the cooking pots are made of a sandy Nile B₂ fabric, Nile E₁, a fabric tempered with sand and straw, or Nile E₃, a coarse fabric tempered with sand and chaff, with abundant quartz particles (>0.25 mm).

One of the *bowls*, *No. 28* (Inv. No. 9075W₁₋₂, Fig. 4:d),²³ is made of Nile C₂, a coarse fabric tem-

⁶ Nile clay tempered with straw, according to the "Vienna system" fabric typology.

⁷ Stratum f = Phase D/2.

⁸ Stratum e/2 = Phase D/2.

⁹ *No. 4* (Inv. No. 9071A, Fig. 1:d; stratum e/1 = Phase D/1); *No. 23* (Inv. No. 9075Y, Fig. 3:g) and *No. 26* (Inv. No. 9071M, Fig. 4:b), stratum c = Phase C/2.

¹⁰ *No. 9* (Inv. No. 9079B, Fig. 2:a; stratum d = Phase C/3) and *No. 25* (Inv. No. 9079C, Fig. 4:a; stratum c).

¹¹ *No. 3* (Inv. No. 9071O, Fig. 1:c), stratum e/1.

¹² *No. 5* (Inv. No. 9071Y, Fig. 1:e), stratum e/1.

¹³ *No. 24* (Inv. No. 9075Z, Fig. 3:h), stratum c.

¹⁴ *No. 27* (Inv. No. 9071P, Fig. 4:c), Plate 1:g; stratum c.

¹⁵ *Nos. 6 and 7, 10 and 11, 18 to 20.*

¹⁶ *No. 19* (Inv. No. 9160U, Fig. 3:c), stratum d.

¹⁷ *No. 10* (Inv. No. 9072Z, Fig. 2:b; Plate 1:c), stratum d.

¹⁸ *No. 11* (Inv. No. 9242M, Fig. 2:c), stratum d.

¹⁹ *No. 6* (Inv. No. 9071Q, Fig. 1:f; stratum e/1) and *No. 7* (Inv. No. 9080Q, Fig. 1:g; stratum e/1–d = Phase D/1–C/3).

²⁰ *No. 18* (Inv. No. 9160T, Fig. 3:b), *No. 19* (Inv. No. 9160U, Fig. 3:c) and *No. 20* (Inv. No. 9078Y, Fig. 3:d), stratum d–c = Phase C/3–C/2.

²¹ Fragments of five bowls.

²² Fragments of ten cooking pots.

²³ Stratum c.

pered with chaff, and decorated with a black polished zone (2.5YR 5/1 reddish grey) on a red slip. The interior is matte with sharp striation marks. Another, *No. 12* (Inv. No. 9242J, Fig. 2:d),²⁴ is made of Nile C₁, with an incised decoration on the smoothed surface, and black polished interior.

Three are body sherds from *bowls with an impressed decoration* made with a toothed wheel on the wet surface. *No. 13* (Inv. No. 9078W, Fig. 2:e) and *No. 14* (Inv. No. 9079A, Fig. 2:f),²⁵ are made of Nile B₂, with the groundmass of fine to medium quality, and black polished interior. *No. 21* (Inv. No. 9078X, Fig. 3:e; Plate 1:e)²⁶ is made of Nile C₁/Nile C₂, with scraping marks inside.

Some *cooking pots*, such as *No. 29* (Inv. No. 9075U, Fig. 4:e) and *No. 30* (Inv. No. 9075V, Fig. 4:f), have the exterior surface covered with a red slip (2.5YR 4/8–5/8), polished with high to medium lustre, and the interior matte with striation marks, made of a sandy Nile B₂ fabric. They were found in contexts from stratum c (= Phase C/2).

Other *cooking pots* present an *incised decoration* (*Nos. 8, 15, 16, 22* and *No. 17*). *No. 8* (Inv. No. 9071H, Fig. 1:h; Plate 1:a)²⁷ is a rim sherd from a convex-sided vessel, 26 cm in diameter and 0.55 cm of wall thickness, decorated on the light brown surface with a horizontal incised line on the rim, and with some obliquely incised lines below; the interior is uneven. *No. 15* (Inv. No. 9079X, Fig. 2:g)²⁸ preserves a pattern of obliquely incised lines made on the light brown surface; the interior is black with polishing marks. Both are made of a sandy Nile B₂ fabric. *No. 16* (Inv. No. 9072D, Fig. 2:h; Plate 1:d)²⁹ and *No. 22* (Inv. No. 9080N, Fig. 3:f)³⁰ have the same decoration. The interior is black and polished, the fabric Nile E₁, the groundmass of medium quality, and the wall thickness between 0.70 and 1.30 cm. *No. 17* (Inv. No. 9071G, Fig. 3:a; Plate 1:b)³¹ is a rim sherd from another convex-sided cooking pot, 22 cm in diameter and 0.60 cm of wall thickness. It has horizontal incised lines on the black-topped polished rim, and a pattern of obliquely incised lines below, made on the light brown smoothed surface. The interior is black and polished with high

lustre; the fabric is Nile E₃ and the groundmass of medium quality.

Three *cooking pots* have an *impressed decoration* made with a toothed wheel, in a sandy Nile B₂ fabric. The interior of the cooking pots *No. 31* (Inv. No. 9075X, Fig. 4:g; Plate 1:h) and *No. 32* (Inv. No. 9080E, Fig. 4:h) is grey or light brown and only smoothed. *No. 33* (Inv. No. 9080F, Fig. 5:a) has a reddish grey to pinkish grey interior surface, polished with low lustre. All of them come from stratum c contexts.

The "Classic" Kerma sherds found in contexts of the late 18th Dynasty onwards are considered residual material. One of them, *No. 34* (Inv. No. 9075T; Fig. 5:b) comes from the foundation trench of the wall M1204, with Egyptian pottery dated to the reign of Horemheb (stratum b/2 = Phase B/3).³² It is a coarse body sherd from a bowl (?), 1.35 cm thick, made of a sandy Nile C₁ fabric (tempered with chaff and sand), uncoated outside and black polished inside (medium lustre). The other three (from stratum b/3 = Phase C/1 to recent time?) are sherds from a beaker and two cooking pots. *No. 35* (Inv. No. 9072H, Fig. 5:c) is the body sherd of a *beaker*, made of Nile B₂, decorated with a grey (matte) zone above the black-topped one polished with high lustre, and black polished inside. *No. 36* (Inv. No. 9070Z, Fig. 5:d; Plate 1:f) is the rim sherd of one of the *cooking pots*, slightly convex-sided, made of Nile E₁, with a black-topped rim, and polished outside and inside; and *No. 37* (Inv. No. 9071B, Fig. 5:e) the body sherd of another, made of Nile E₃, decorated with a pattern of incised lozenges outside and black polished inside.

CONCLUSIONS

The Kerma pottery found in the palace district at ^cEzbet Helmi provides more archaeological evidence on the presence of Kerma people in Egypt during the 18th Dynasty. The existence of Kerma pottery in Egypt is related to the contacts with this culture, but especially, first to the Egyptian reoccupation of Lower Nubia, and then to the

²⁴ Stratum d.

²⁵ Both are from stratum d.

²⁶ Stratum d–c.

²⁷ Stratum e/1–d (= Phase D/1–C/3).

²⁸ Stratum d.

²⁹ Stratum d.

³⁰ Stratum d–c.

³¹ Stratum d.

³² BIETAK, DORNER, & JÁNOSI, *Ä&L* 11 (2001) 11 and 101–102 (7.- Ein Festungsbau der Zeit des Tutanchamun und des Haremhab) and fig. 33.

destruction of Kerma in the Dongola basin and the domination of Upper Nubia until the south of the 4th cataract. This situation explains the presence of Kerma people at the end of the Second Intermediate Period (during the late 17th Dynasty) and the early 18th Dynasty in Upper Egypt, at the beginning of the New Kingdom in the Memphis-Fayum region, and at the end of the Hyksos rule (late 15th Dynasty) and the early and early-middle 18th Dynasty in Tell el-Dab^ca/Avaris. Besides the Kerma pottery, silex arrow points, Nubian skulls and male bodies in soldier burials were found at ^cEzbet Helmi in strata of the beginning of the 18th Dynasty. Kerma people could have arrived at Avaris first as mercenaries with Ahmose's army and then, after the defeat of Kerma, as prisoners of war with Thutmose III.³³

All the Kerma ceramics found at ^cEzbet Helmi in contexts from the late 18th dynasty onwards must be considered residual material.

THE CATALOGUE³⁴

I. The “Classic” Kerma pottery in contexts of the Second Intermediate Period

A. Late Hyksos Period (Phase D/2)

Fine ware (black-topped red polished ware)
Beakers in Nile B₂

No. 1 (Fig. 1:a), 9071W {2003/038}

[RP]SP	I-b-2 ³⁵	f-mi	Ha1	—	re	2-3
--------	---------------------	------	-----	---	----	-----

Wd: 0.40 cm.

Surface colour: 7.5YR 2.5/1 black.

Break: 5YR 4/1 dark grey.

Fabric: Nile B₂; straw (few) tempered.

Technical details: polishing marks inside.

Decoration: a black-topped zone below [the rim].

Surface treatment: polished, high lustre outside and inside.

Field reference: H/VI-w/16, Pl. 8–9, **L4783** (mud-brick debris on the wall M1501. H:3.10–2.90 m), stratum f (= Phase D/2).

No. 2 (Fig. 1:b), 9071K {2003/010}

RPSP	I-b-2	mi	Ha1	—	re	2-3
------	-------	----	-----	---	----	-----

Body sherd. Wd: 0.40 cm.

Surface colour: 2.5YR 4/4 reddish brown slip outside; 5YR 2.5/1 black inside.

Break: 5YR 3/1 very dark grey.

Fabric: Nile B₂; straw tempered.

Surface treatment: polished, high lustre outside and inside.

Field reference: H/VI-x/18, Pl. 5–6, **L5028** (a burnt layer), stratum e/2 (= Phase D/2).

II. The “Classic” Kerma pottery in contexts of the 18th Dynasty

A. Early 18th Dynasty (Phase D/1)

Fine ware (black-topped red polished ware)

1. Beakers in Nile B₂

No. 3 (Fig. 1:c), 9071O {2003/020}

RPSP	I-b-2	f-mi	Ha1	—	re	2-3
------	-------	------	-----	---	----	-----

Body sherd. Wd: 0.30 cm.

Surface colour: 10R 5/6 red slip outside; 5YR 2.5/1 black polished inside.

Break: 2.5YR 3/1 dark reddish grey.

Fabric: Nile B₂; straw tempered.

Technical details: polishing marks inside.

Decoration: a black-topped [rim]; a matte grey zone (5YR 6/1 and 5/1) between the red-slipped polished body and the black rim.

Surface treatment: polished, high lustre inside and matte below the [rim].

Field reference: H/III-o/14, Pl. 7–8, **L2173** (a sandy layer with a large amount of sherds. H: 2.80–2.90 m; 2.50–4.50 m E, 4.00 m N), stratum e/1 (= Phase D/1).

No. 4 (Fig. 1:d), 9071A {2003/010}

RPSP	I-b-2	f-mi	Ha1	—	m	2-3
------	-------	------	-----	---	---	-----

Body sherd. Wd: 0.40 cm.

Surface colour: 7.5YR 6/3 light brown; 10R 5/6 red slip outside; 7.5YR 2.5/1 black inside.

³³ See FUSCALDO, *Ä&L* 14, 113 and the references mentioned in notes 19 to 22.

³⁴ Explanations of the vessel description: above the boxes there are the inventory number of the vessel, the drawing number in the records of the Mission and the year when it was drawn; inside the boxes, there are mentioned different attributes: ware, fabric in the

Tell el-Dab^ca system, quality of the groundmass, method of manufacture, shaping technique of the base, firing index and hardness, according to the “Keramikinventar”.

³⁵ I-b-2 is a fabric designation in the Tell el-Dab^ca system, Nile clay with rounded sand grains, feldspar and mica, tempered with straw (Nile B₂ in the “Vienna system”).

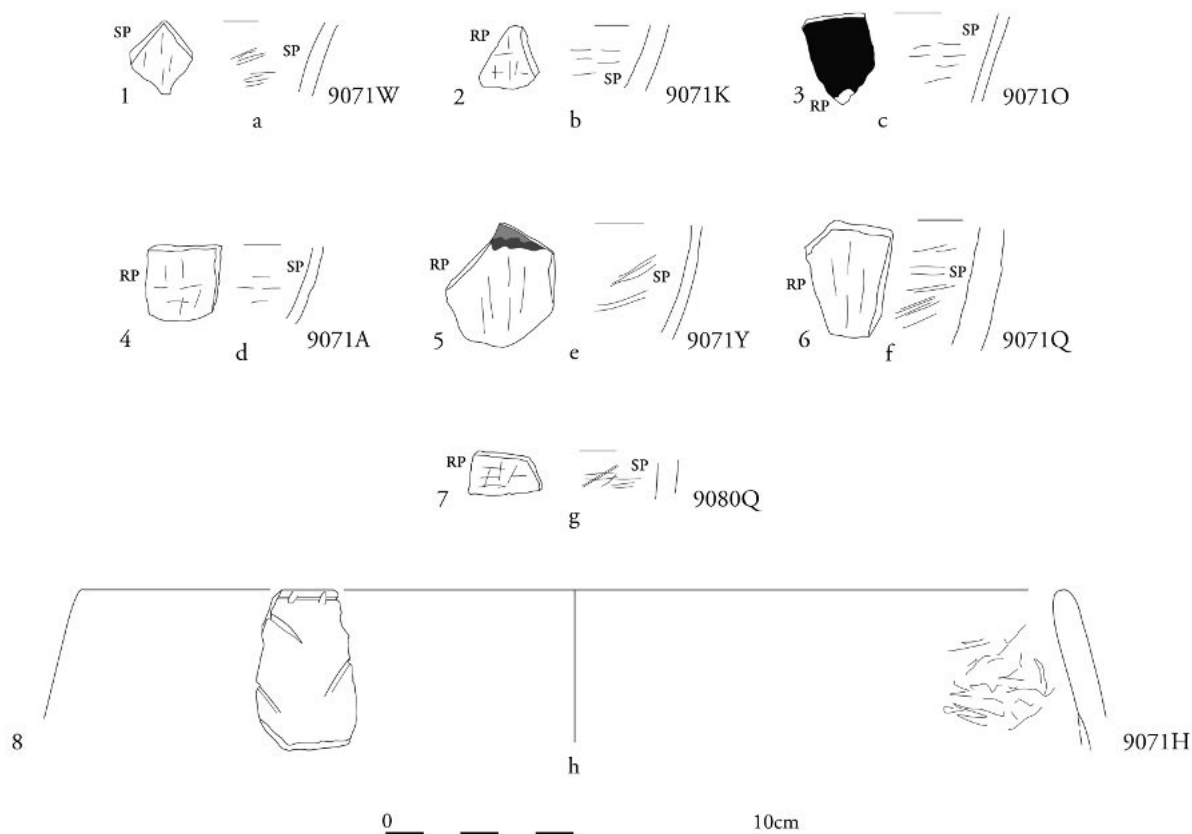

Fig. 1

Break: 7.5YR 3/1 very dark grey interior; 7.5YR 4/3 brown exterior.

Fabric: Nile B₂; straw tempered.

Technical details: polishing marks inside.

Surface treatment: polished, medium lustre outside and high lustre inside.

Field reference: H/VI-x/19, Pl. 3, **L4973** (a sherd carpet which goes over walls M1581 and M1582, possibly a continuation of L4926. H: 4.55–4.62 m), stratum e/1.1 (= Phase D/1.1).

No. 5 (Fig. 1:e), 9071Y {2003/039}

RPSP	I-b-2	f-mi	Ha1	—	ox	2-3
------	-------	------	-----	---	----	-----

Body sherd. Wd: 0.35 cm.

Surface colour: 2.5YR 4/8 red slip outside; 5YR 2.5/1 black inside.

Break: 2.5YR 5/6 red.

Fabric: Nile B₂; straw tempered.

Technical details: polishing marks inside.

Decoration: a black-topped zone, 5YR 7/2 pinkish grey; below: grey (Chart 1 for gley, N5/1).

Surface treatment: polished, high lustre outside and inside.

Field reference: H/VI, x/19, Pl. 3, **L4975** (from outside the silos. H: 4.35–4.42 m), stratum e/1.2 (= Phase D/1.2).

2. Bowls in Nile B₂

No. 6 (Fig. 1:f), 9071Q {2003/020}

RPSP	I-b-2	mi	Ha1	—	m	2-3
------	-------	----	-----	---	---	-----

Body sherd. Wd: 0.70 cm.

Surface colour: 5YR 6/4 light reddish brown; 10R 5/6 red slip outside; 5YR 2.5/1 black inside.

Break: 5YR 5/4 reddish brown outside (thick); 4/1 dark grey inside (thin).

Fabric: Nile B₂; straw tempered.

Surface treatment: polished, high lustre.

Field reference: H/VI-v/18, Pl. 4, **L4999** (debris on a burnt surface. H: 3.92–4.10 m), stratum e/1 (= Phase D/1).

B. Early to early-middle 18th dynasty (Phase D/1–C/3)

1. Fine ware (black-topped red polished ware)

Bowls in Nile B₂

No. 7 (Fig. 1:g), 9080Q {2006/167}

Body sherd. Wd: 0.40 cm.

RPSP	I-b-2	mi	Ha1	—	ox	2-3
------	-------	----	-----	---	----	-----

Surface colour: 2.5YR 6/4 light reddish brown slip outside; 2.5YR 5/1 reddish grey inside.

Break: 2.5YR 4/1 dark reddish grey core; 2.5YR 6/3 light red and 5/3 reddish brown oxidation zones.

Fabric: Nile B₂; straw tempered.

Surface treatment: polished outside and inside, medium lustre.

Field reference: H/III-n/16, Pl. 1–2, **L2169**, a mud layer below L2017. Stratum e/1–d (= Phase D/1–C/3).

2. General household ware

Cooking pots in Nile B₂ (sandy) with incised decoration

No. 8 (Fig. 1:h; Plate 1:a), 9071H {2003/008}

TG	I-b-2 s. ³⁶	mi	Ha1	—	re	2
----	------------------------	----	-----	---	----	---

Rim sherd, 1/32 preserved; convex sided.

Rd: 26.00 cm; Md: 28.00 + x cm; Wd: 0.55 cm; H₁: 4.40 + x cm.

Surface colour: 7.5YR 6/4 light brown.

Break: 7.5YR 4/3 brown.

Fabric: Nile B₂ sandy; sand (few) and straw tempered.

Decoration: a horizontal incised line on the rim, and a pattern of obliquely incised lines below.

Surface treatment: uneven inside.

Field reference: H/VI-u/19, Pl. 2–3, **L4126** (an accumulation of ash and humus-soil with mud-brick debris), stratum e/1–d (= Phase D/1–C/3).

C. Early–middle 18th dynasty (Phase C/3)

1. Fine ware (black-topped red polished ware)

1.1. Beakers in Nile B₂

No. 9 (Fig. 2:a), 9079B {2005/136}

SP	I-b-2	mi	Ha1	—	re	2–3
----	-------	----	-----	---	----	-----

Body sherd. Wd. 0.30 cm.

Surface colour: 7.5YR 2.5/1 black outside and inside.

Break: 7.5YR 2.5/1 black.

Fabric: Nile B₂; straw tempered.

Decoration: a black-topped zone below [the rim]. Surface treatment: polished, high lustre outside and inside.

Field reference: H/VI-w/16, Pl. 2–3, **L4604**, a mud layer below L4568 (a rubbish area). Stratum d (= Phase C/3).

1.2. Bowls in Nile B₂

No. 10 (Fig. 2:b; Plate 1:c), 9072Z {2005/151}

RPSP	I-b-2	mi	Ha1	—	re	2–3
------	-------	----	-----	---	----	-----

Rim sherd, 1/64 preserved; convex sided.

Rd: 16.00 cm; Md: 19.00 + x cm; Wd: 0.50 cm; H₁: 3.00 + x cm.

Surface colour: 7.5YR 2.5/1 black inside; 10R 5/4–4/4 weak red slip outside.

Break: 7.5YR 2.5/1 black.

Fabric: Nile B₂; straw tempered.

Technical details: polishing marks inside.

Decoration: a very dark grey (7.5YR 3/1) rim band.

Surface treatment: polished outside and inside, high lustre.

Field reference: H/VI-t/13, Pl. 2–3, **L4043** (the sandy-mud fill of the room below the floor. H: 4.60–4.90 m), stratum d (= Phase D/3).

No. 11 (Fig. 2:c), 9242M {2006/499}

RPTG	I-b-2	mi	Ha1	—	re	2–3
------	-------	----	-----	---	----	-----

Body sherd. Wd: 0.40–0.50 cm.

Surface colour: 5YR 5/1 grey inside; 2.5YR 5/4 reddish brown slip outside.

Break: 5YR 5/3 reddish brown core; 5YR 4/1 dark grey outside and inside.

Fabric: Nile B₂; straw tempered.

Decoration: a black-topped zone, 5YR 4/1 dark grey and 2.5/1 black.

Surface treatment: polished outside, medium lustre; uneven inside.

Field reference: H/VI-m/20, Pl. 0–1, **L6051** (the fill of the so-called “Vestibule”, in the southern part of the Palace G. H: 4.36–4.78 m), stratum d (= Phase C/3).

2. General household ware

2.1. Bowls

Incised decoration

No. 12 (Fig. 2:d), 9242J {2006/499}

TGSP	I-c-1	mi	Ha1	—	re	2–3
------	-------	----	-----	---	----	-----

Body sherd. Wd: 0.65 cm.

Surface colour: 5YR 5/2 reddish grey outside; 5YR 2.5/1 black inside.

Break: 5YR 2.5/1 black inside (thick); 5/4 reddish brown outside (thin).

Fabric: Nile C₁; chaff (few) tempered.

Technical details: polishing marks inside.

Decoration: incised.

Surface treatment: polished inside, medium lustre.

³⁶ I-b-2 s. is a sandy Nile B₂ fabric.

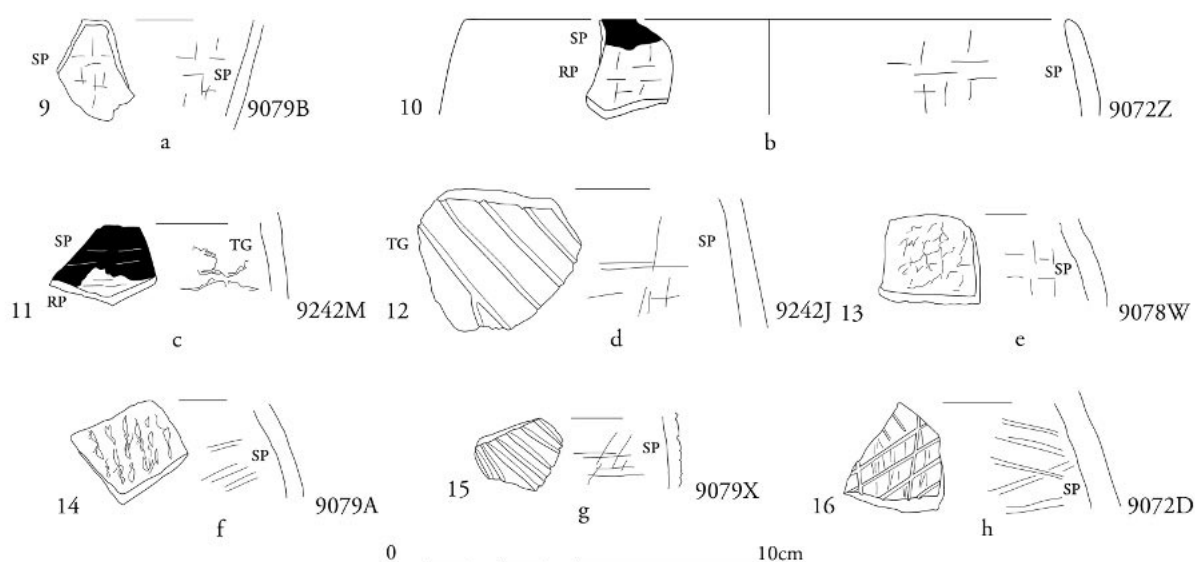

Fig. 2

Field reference: H/VI-m/19, Pl. 0–1, **L6051** (the fill of the so-called “Vestibule”, in the southern part of the Palace G. H: 4.36–4.78 m), stratum d (= Phase C/3).

Impressed decoration

No. 13 (Fig. 2:e), 9078W {2005/137}

TGSP	I-b-2	f-mi	Ha1	—	re	2–3
------	-------	------	-----	---	----	-----

Body sherd. Wd. 0.50 cm.

Surface colour: 5YR 6/4 light reddish brown outside; 5YR 2.5/1 black inside.

Break: 2.5YR 4/6 red outside; 3/1 dark reddish grey inside.

Fabric: Nile B₂; straw tempered.

Decoration: impressed decoration made with a toothed wheel, bad preserved (eroded).

Surface treatment: polished inside, high lustre.

Field reference: H/VI-m/19, Pl. 0–1, **L6051** (mud-brick debris on the surface of L4780), stratum d (= Phase C/3).

No. 14 (Fig. 2:f), 9079A {2005/136}

TGSP	I-b-2	f-mi	Ha1	—	re	2–3
------	-------	------	-----	---	----	-----

Body sherd. Wd. 0.60 cm.

Surface colour: 7.5YR 6/3–6/4 light brown outside; 5/1 grey inside.

Break: 7.5YR 5/4–4/4 brown outside; 2.5/1 black inside.

Fabric: Nile B₂; straw tempered.

Technical details: polishing marks inside.

Decoration: impressed decoration made with a toothed wheel (eroded).

Surface treatment: polished, low lustre inside.

Field reference: H/VI-w/16, Pl. 2–3, **L4604**, a mud layer below L4568 (a rubbish area). Stratum d (= Phase C/3).

2.2. Cooking pots with incised decoration in Nile B₂ (sandy) and Nile E

No. 15 (Fig. 2:g), 9079X {2006/164}

TGSP	I-b-2 s.	mi	Ha1	—	re	2–3
------	----------	----	-----	---	----	-----

Body sherd. Wd. 0.40 cm.

Surface colour: 7.5YR 6/4 light brown outside; 7.5YR 2.5/1 black inside.

Break: 7.5YR 3/1 very dark grey.

Technical details: striation marks inside.

Fabric: Nile B₂ sandy; sand (some) and straw (few) tempered.

Decoration: a pattern of obliquely incised lines.

Surface treatment: polished inside, medium lustre.

Field reference: H/III-n/14, Pl. 2–3, **L2125** (the mud fill of the foundation trench for the wall M1001), stratum d (= Phase C/3).

No. 16 (Fig. 2:h; Plate 1:d), 9072D {2003/038}

TGSP	I-e-1	mi	Ha1	—	re	2
------	-------	----	-----	---	----	---

Body sherd. Wd: 0.70 cm.

Surface colour: 7.5YR 6/2 pinkish grey-5/1 grey; 7.5YR 2.5/1 black inside.

Fabric: Nile E₁; sand and straw (few) tempered.

Break: 5YR 2.5/1 black.

Technical details: striation marks inside.

Decoration: a pattern of obliquely incised lines.

Surface treatment: polished inside, medium lustre.

Field reference: H/VI-x/18, Pl. 1, **L4839** (the large courtyard of Palace J), stratum d (= Phase C/3).

No. 17 (Fig. 3:a; Plate 1:b), 9071G {2003/008}

TGSP	I-e-3	mi	Ha1	—	re	2-3
------	-------	----	-----	---	----	-----

Rim sherd, 1/32 preserved; convex sided.

Rd: 22.00 cm; Md: 25.00 + x cm; Wd: 0.60 cm; H₁: 3.00 + x cm.

Surface colour: 7.5YR 6/3 light brown outside; 7.5YR 2.5/1 black inside.

Break: 7.5YR 2.5/1 black.

Fabric: Nile E₃. Inclusions: quartz (>0.25 mm: abundant); sand and chaff tempered.

Technical details: burnishing marks inside.

Decoration: horizontally incised lines on the black-topped polished rim, and a pattern of obliquely incised lines below.

Surface treatment: polished inside, high lustre.

Field reference: H/III-t/17, Pl. 3-4, **L1058** (material produced by the excavation of the foundation trench), stratum d (=Phase C/3).

Phase C/3-C/2

1. Fine ware (black-topped red polished ware)

Bowls

No. 18 (Fig. 3:b), 9160T {2007/150}

RPSP	I-b-2	mi	Ha1	—	re	2-3
------	-------	----	-----	---	----	-----

Body sherd. Wd: 0.65 cm.

Surface colour: 10R 5/6 red slip outside; 2.5Y 4/1 dark grey inside.

Break: 7.5YR 2.5/1 black.

Fabric: Nile B₂; straw tempered.

Decoration: 10R 5/3 weak red below the [rim].

Surface treatment: polished, medium lustre outside, high lustre inside.

Field reference: H/VI-q/14, Pl. 0-1, **L6345** (the mud fill with mud-brick debris and pottery inside the interior room. H: 4.61-4.65 m), stratum d-c (= Phase C/3-C/2).

No. 19 (Fig. 3:c), 9160U {2007/090}

SP	I-c-1 ³⁷	mi	Ha1	—	re	2-3
----	---------------------	----	-----	---	----	-----

Body sherd. Wd: 0.70 cm.

Surface colour: 10YR 4/1 dark grey outside; 3/1 very dark grey inside.

Break: 5YR 4/4 reddish brown core; 7.5YR 4/3 brown and 3/3 dark brown outside and inside.

Fabric: Nile C₁; chaff (few) tempered.

Technical details: polishing marks inside.

Surface treatment: polished, medium lustre outside and high lustre inside.

Field reference: H/III-t/18, Pl. 1-2, **L1002** (mud-brick debris 10 cm above the surface of Pl. 2), stratum d-c (= Phase C/3-C/2).

No. 20 (Fig. 3:d), 9078Y {2005/136}

RPSP	I-b-2	mi	Ha1	—	re	2-3
------	-------	----	-----	---	----	-----

Body sherd. Wd. 0.65 cm.

Surface colour: 5YR 4/1 dark grey inside; 10R 5/6 red slip outside.

Break: 5YR 2.5/1 black.

Fabric: Nile B₂; straw tempered.

Technical details: polishing marks inside.

Surface treatment: polished, high lustre outside and low lustre inside.

Field reference: H/VI-t/13, Pl. 3-4, **L4053** (humus-soil deposition by human activity), stratum d-c (= Phase C/3-C/2).

2. General household ware

2.1. Bowls with impressed decoration

No. 21 (Fig. 3:e; Plate 1:e), 9078X {2005/136}

TG	I-c-1/I-c-2 ³⁸	mi	Ha1	—	re	2-3
----	---------------------------	----	-----	---	----	-----

Body sherd. Wd. 0.70 cm.

Surface colour: 5YR 5/3 reddish brown outside; 5YR 2.5/1 black inside.

Break: 5YR 4/3 reddish brown outside; 3/3 dark reddish brown inside.

Fabric: Nile C₁/Nile C₂; chaff tempered.

Technical details: scraping marks inside.

Decoration: impressed decoration made with a toothed wheel.

Surface treatment: smoothed.

Field reference: H/VI-t/13, Pl. 3-4, **L4053** (humus-soil deposition by human activity), stratum d-c (= Phase C/3-C/2).

³⁷ I-c-1 is a fabric designation in the Tell el-Dab^ca system, Nile clay with rounded sand grains, feldspar and mica, tempered with few amount of chaff (Nile C₁ in the "Vienna system").

³⁸ I-c-2 is a fabric designation in the Tell el-Dab^ca system, Nile clay with rounded sand grains, feldspar and mica, tempered with chaff (Nile C₂ in the "Vienna system"); a coarse fabric.

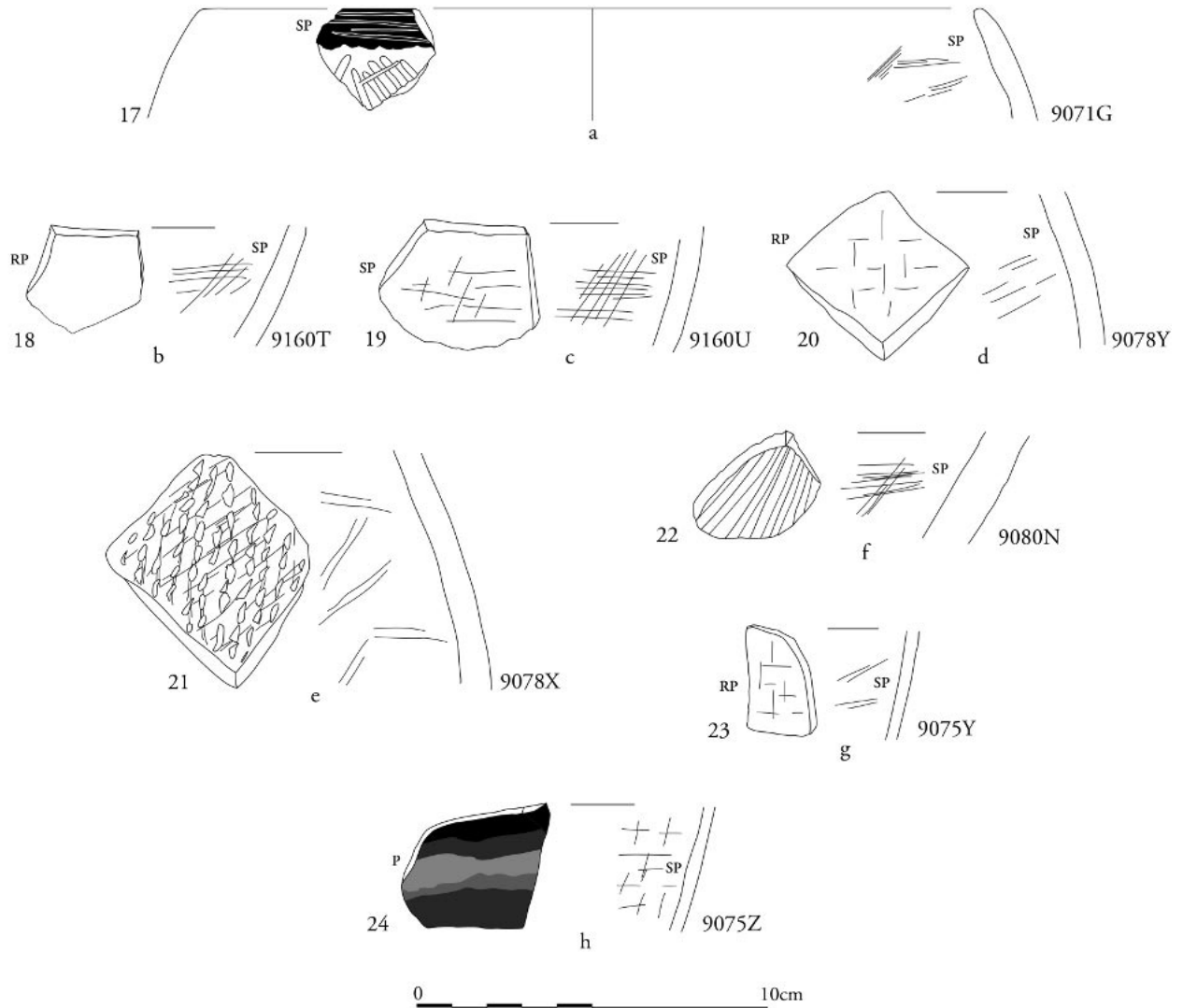

Fig. 3

2.2. Cooking pots in Nile E₁ with incised decoration

No. 22 (Fig. 3:f), 9080N {2006/164}

TGSP	I-e-1 ³⁹	mi	Ha1	—	re	2
------	---------------------	----	-----	---	----	---

Body sherd. Wd. 1.30 cm.

Surface colour: 7.5YR 7/3 pink outside; 4/1 dark grey inside.

Break: 7.5YR 3/1 very dark grey.

Fabric: Nile E₁; sand and straw (few) tempered.

Technical details: polishing marks inside.

Decoration: obliquely incised lines.

Surface treatment: polished inside, low lustre.

Field reference: H/III-o/13, Pl. 1, wall M2005 (the western part of exterior wall of the Palace G), stratum d-c (= Phase C/3-C/2).

Phase C/2

1. Fine ware (black-topped red polished ware)

Beakers in Nile B₂

No. 23 (Fig. 3:g), 9075Y {2005/151}

RPSP	I-b-2	f-mi	Ha1	—	re	2-3
------	-------	------	-----	---	----	-----

Body sherd. Wd. 0.35 cm.

Surface colour: 5YR 6/4 light reddish brown; 2.5YR 5/8 red slip outside; 2.5YR 4/1 dark reddish grey inside.

Break: 5YR 2.5/1 black.

Fabric: Nile B₂; straw tempered.

Surface treatment: polished, medium lustre outside and low lustre inside.

³⁹ I-e-1 is a fabric designation in the Tell el-Dab^a system, Nile clay with rounded sand grains, feldspar and mica,

tempered with sand and straw (Nile E₁ in the “Vienna system”).

Field reference: H/VI-v/17, Pl. 5–6, wall **M1201**, stratum c (= Phase C/2).

No. 24 (Fig. 3:h, Plate 1:g), 9075Z {2005/137}

RPSP	I-b-2	f-mi	Ha1	—	re	2-3
------	-------	------	-----	---	----	-----

Body sherd. Wd. 0.35 cm.

Surface colour: 2.5YR 5/6 red slip outside; 7.5YR 2.5/1 black inside.

Break: 7.5YR 2.5/1 black.

Fabric: Nile B₂; straw tempered.

Decoration: a black-topped zone (7.5YR 2.5/1 black on the top and 3/1 very dark grey below); the transition section to the black-topped zone in dusky red (10R 3/4) and bluish grey (5/1–6/1, Chart 2 for gley).

Surface treatment: polished, high lustre outside and in the upper part of the interior; low lustre in the lower part of the interior.

Field reference: H/VI-t/16–17, Pl. 1, **L6024** (the fill of the “street”, by the exterior wall of the Palace G. H: 4.77–4.88 m), stratum c (= Phase C/2).

No. 25 (Fig. 4:a), 9079C {2005/136}

SP	I-b-2	f-mi	Ha1	—	re	2-3
----	-------	------	-----	---	----	-----

Body sherd. Wd. 0.30 cm.

Surface colour: 7.5YR 2.5/1 black outside and inside.

Break: 7.5YR 2.5/1 black.

Fabric: Nile B₂; straw tempered.

Decoration: a black-topped zone below [the rim]. Surface treatment: polished, high lustre outside and inside.

Field reference: H/VI-v/16, Pl. 2–3, wall **M1203**, stratum c (=Phase C/2).

No. 26 (Fig. 4:b), 9071M {2003/021}

RPSP	I-b-2	mi	Ha1	—	re	2-3
------	-------	----	-----	---	----	-----

Body sherd. Wd: 0.25 cm.

Surface colour: 10R 5/6 red slip outside; 5YR 2.5/1 black inside.

Break: 2.5YR 3/1 dark reddish grey.

Fabric: Nile B₂; straw tempered.

Technical details: polishing marks inside.

Surface treatment: polished, high lustre outside and inside.

Field reference: H/III-p/16, Pl. 1, **L2017** (debris with plaster), stratum c (= Phase C/2).

No. 27 (Fig. 4:c), 9071P {2003/021}

RPSP	I-b-2	f-mi	Ha1	—	re	2-3
------	-------	------	-----	---	----	-----

Body sherd. Wd: 0.40 cm.

Surface colour: 7.5YR 5/4 brown; 10R 5/6 red

slip outside; 5YR 2.5/1 black inside.

Break: 5YR 2.5/1 black.

Fabric: Nile B₂; straw tempered.

Decoration: a black-topped [rim]; matte black (5YR 2.5/1), very dark grey (5YR 3/1), grey (Chart 1 for gley N6) and weak red (10R 4/3) zones below the [rim].

Surface treatment: polished, high lustre inside and matte below the [rim].

Field reference: H/III-o-/16, section, **L2017** (from the baulk section. H: ca. 4.15 m; 1.50 m W), stratum c (= Phase C/2).

2. General household ware

2.1. Bowls

No. 28 (Fig. 4:d), 9075W₁₋₂ {2005/138}

RPS	I-c-2	mi	Ha1	—	re	2-3
-----	-------	----	-----	---	----	-----

Body sherd. Wd: 0.75 cm.

Surface colour: 7.5YR 4/1 dark grey-3/1 very dark grey inside; 2.5YR 5/6 red slip outside.

Break: 5YR 2.5/1 black.

Technical details: striation marks inside (matte).

Fabric: Nile C₂; chaff tempered.

Decoration: a black topped [rim] (2.5YR 5/1 reddish grey), fragment 2.

Surface treatment: polished outside, medium lustre.

Field reference: H/VI-v/17, Pl. 5–6, wall **M1201**, stratum c (= Phase C/2).

2.2. Cooking pots in Nile B₂ (sandy)

No. 29 (Fig. 4:e), 9075U {2005/137}

RPS	I-b-2 s.	mi	Ha1	—	re	2-3
-----	----------	----	-----	---	----	-----

Body sherd. Wd: 0.95 cm.

Surface colour: 5YR 3/1 very dark grey inside; 2.5YR 4/8 red slip outside.

Break: 5YR 2.5/1 black.

Fabric: Nile B₂ sandy; sand (some) and straw (few) tempered.

Technical details: striation marks inside (matte); a hole in the wall.

Surface treatment: polished outside, high lustre.

Field reference: H/VI-v/17, Pl. 5–6, wall **M1201**, stratum c (= Phase C/2).

No. 30 (Fig. 4:f), 9075V {2005/138}

RPS	I-b-2 s.	mi	Ha1	—	re	2-3
-----	----------	----	-----	---	----	-----

Body sherd. Wd: 1.15 cm.

Surface colour: 2.5YR 2.5/1 reddish black inside; 2.5YR 5/8 red slip outside.

Break: 7.5YR 2.5/1 black.

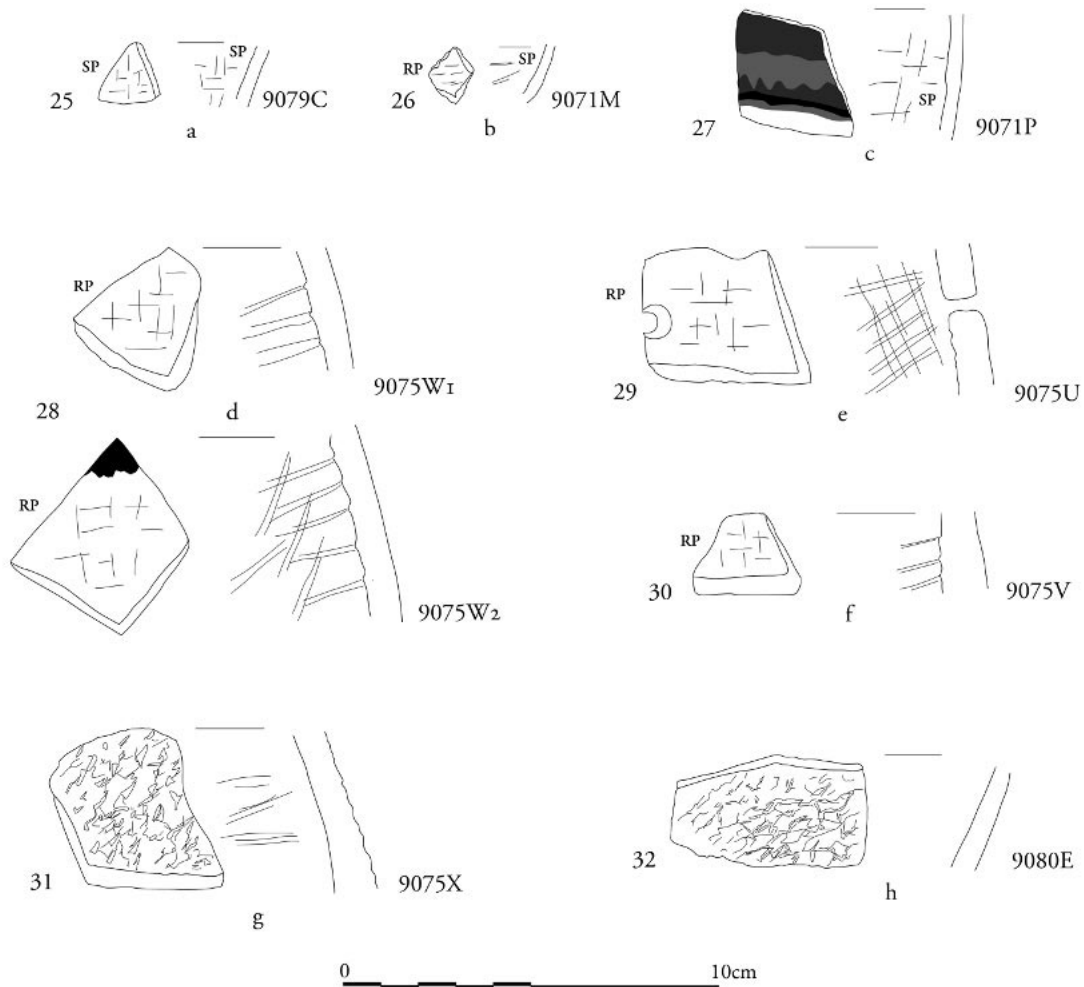

Fig. 4

Fabric: Nile B₂ sandy; sand (some) and straw (few) tempered.

Technical details: striation marks inside.

Surface treatment: polished outside, medium lustre; matte inside.

Field reference: H/VI-v/15, Pl. 2, wall **M1201A**, stratum c (= Phase C/2).

Impressed decoration

No. 31 (Fig. 4:g, Plate 1:h), 9075X {2005/138}

TG	I-b-2 s.	mi	Ha1	—	m	2-3
----	----------	----	-----	---	---	-----

Body sherd. Wd. 0.90 cm.

Surface colour: 5YR 5/4 reddish brown outside; 6/1 grey inside.

Break: 5YR 4/4 reddish brown outside; 5/2 reddish grey inside.

Fabric: Nile B₂ sandy; sand (some) and straw (few) tempered.

Technical details: striation marks inside (matte).

Decoration: impressed decoration made with a toothed wheel.

Surface treatment: smoothed.

Field reference: H/VI-v/17, Pl. 5-6, wall **M1201**, stratum c (= Phase C/2).

No. 32 (Fig. 4:h), 9080E {2006/165}

TG	I-b-2 s.	f-mi	Ha1	—	re	2
----	----------	------	-----	---	----	---

Body sherd. Wd. 0.40 cm.

Surface colour: 7.5YR 6/3 light brown.

Break: 7.5YR 5/3 brown outside; 4/3 brown inside.

Fabric: Nile B₂ sandy; sand (some) and straw (few) tempered.

Decoration: impressed decoration made with a toothed wheel.

Surface treatment: smoothed.

Field reference: H/III-p/16, Pl. 1, **L2017** (debris. H: 3.65-4.98 m), stratum c (= Phase C/2).

No. 33 (Fig. 5:a), 9080F {2006/165}

TGSP	I-b-2 s.	mi	Ha1	—	re	2-3
------	----------	----	-----	---	----	-----

Body sherd. Wd. 0.55 cm.

Surface colour: 5YR 5/6 yellowish red -6/2 pinkish grey outside; 5YR 5/2 reddish grey - 7/2 pinkish grey inside.

Break: 5YR 2.5/1 black.

Technical details: polishing marks inside.

Fabric: Nile B₂ sandy; sand (some) and straw (few) tempered.

Decoration: impressed decoration made with a toothed wheel.

Surface treatment: polished inside, low lustre.

Field reference: H/III-p/16, Pl. 1, **L2017** (debris layer. H: 3.65–4.98 m), stratum c (= Phase C/2).

D. Late 18th Dynasty (Phase B/3)

General household ware, bowls

No. 34 (Fig. 5: b), 9075T {2005/137}

TGSP	I-c-1 s. ⁴⁰	mi-r	Ha1	—	re	2-3
------	------------------------	------	-----	---	----	-----

Body sherd (from a bowl?). Wd: 1.35 cm.

Surface colour: 5YR 5/4–4/3 reddish brown outside; 5YR 2.5/1 black inside.

Break: 5YR 4/3 reddish brown outside; 4/2 dark reddish grey inside.

Fabric: Nile C₁ sandy; sand (some) and chaff (few) tempered.

Technical details: polishing marks inside; eroded outside.

Surface treatment: smoothed outside; polished inside, medium lustre.

Field reference: H/VI-o/17, Pl. 1, **L4009**, the western section of the foundation trench for the wall M1204 (Horemheb), stratum b/2 (= Phase B/3).

E. Late 18th Dynasty to recent times

1. Fine ware (black-topped red polished ware), beakers

No. 35 (Fig. 5: c), 9072H {2003/038}

SP	I-b-2	f-m	Ha1	—	re	2-3
----	-------	-----	-----	---	----	-----

Body sherd. Wd: 0.30 cm.

Surface colour: 5YR 2.5/1 black.

Break: 5YR 2.5/1 black.

Fabric: Nile B₂; straw tempered.

Decoration: matte grey (5YR 6/1) above the black-topped zone (5YR 2.5/1 black, high lustre). Surface treatment: polished outside and inside, high lustre.

Field reference: H/III-n/14, Pl. 0–1, **L2000** (a recent artificial accumulation of sand. H: 4.90–5.00 m), stratum b/3 (= Phase C/1) to recent?

2. General household ware

Cooking pots in Nile E

No. 36 (Fig. 5: d; Plate 1:f), 9070Z {2003/021}

RPP	I-e-1	mi	Ha1	—	ox	2-3
-----	-------	----	-----	---	----	-----

Rim sherd, 1/32 preserved; slightly convex sided.

Rd: 20.00 cm; Wd: 0.45 cm; H₁: 4.00 + x cm.

Surface colour: 10R 5/6 red-2.YR 5/4 reddish brown slip outside; 5YR 5/4 reddish brown inside.

Break: 7.5YR 3/1 very dark grey core; 5YR 5/6 yellowish red oxidation zones.

Fabric: Nile E₁; sand and straw (few) tempered.

Technical details: burnishing marks inside.

Decoration: a black-topped rim (5YR 2.5/1).

Surface treatment: polished, low lustre outside and medium lustre inside.

Field reference: H/III-o/14, Pl. 1, **L2004** (from the upper part of the wall, ca. 4 m), stratum b/3 (= Phase C/1).

No. 37 (Fig. 5: e), 9071B {2003/021}

TGSP	I-e-3 ⁴¹	mi-r	Ha1	—	re	2
------	---------------------	------	-----	---	----	---

Body sherd. Wd: 0.60 cm.

Surface colour: 7.5YR 2.5/1 black. Break: 7.5YR 2.5/1 black.

Fabric: Nile E₃. Inclusions: quartz (>0.25 mm: abundant), mica (few); sand and coarse chaff tempered.

Technical details: burnishing marks inside.

Decoration: a pattern of incised lozenges.

Surface treatment: polished inside, low lustre.

Field reference: H/III-o/14, Pl. 0–1, **L2001** (a sherd collection. H: 4.93–4.85 m), stratum b/3 (= Phase C/1) to recent?

⁴⁰ I-c-1 s. is a sandy Nile C₁ fabric.

⁴¹ I-e-3 is a fabric designation in the Tell el-Dab^ca system,

Nile clay with rounded sand grains, feldspar and mica, tempered with sand and coarse chaff (Nile E₃).

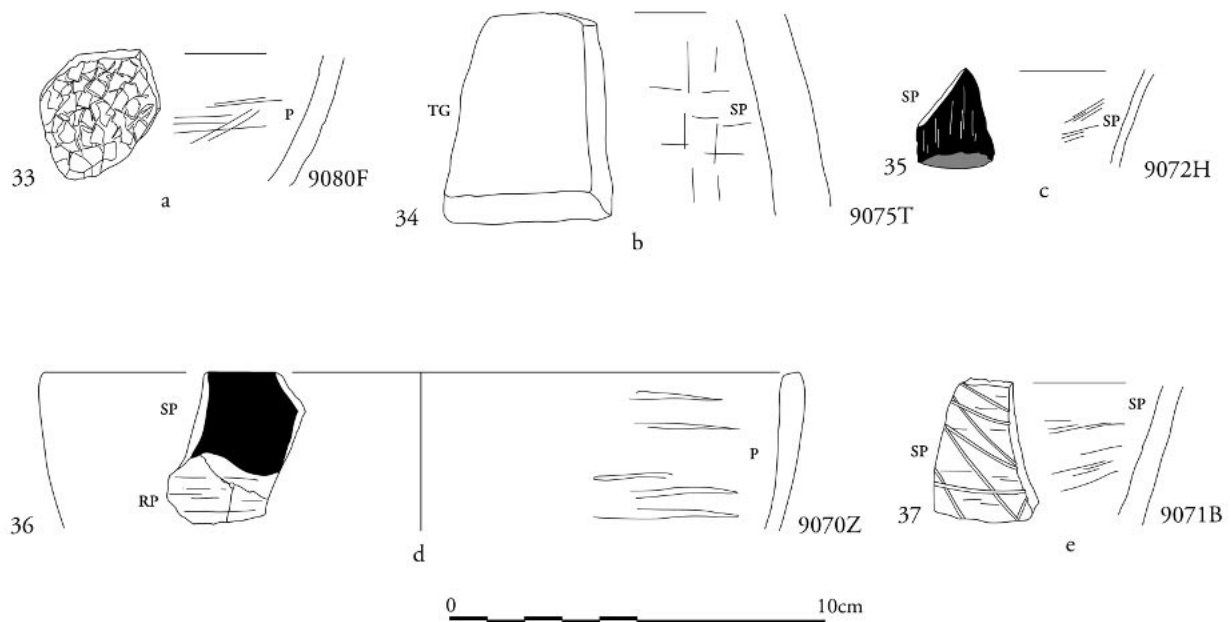

Fig. 5

ADDENDA

I. Distributions of the Kerma sherds by strata

The relative strata at 'Ezbet Helmi are dated to the periods illustrated in Table 1.⁴²

A list of all the Kerma sherds published by the author of this article is included in the Tables and Graphs 2 to 4. It is presented according to the relative stratum where the sherds were found, with references to the inventory number, typology, parts preserved, fabric, decoration, Kerma chronology, area and locus number, and publication. Their distribution by periods is also presented in the Table and Graph 5.

The complete reference to the publication is as follows: P. FUSCALDO, *The Nubian Pottery from the Palace District of Avaris at 'Ezbet Helmi, Areas H/III and H/VI*,

Part I: The "Classic" Kerma Pottery from the 18th Dynasty, in *Ä&L* 12 (2002) 167–189;

Part II: The "Classic" Kerma Pottery from the

Second Intermediate Period and the 18th Dynasty, in *Ä&L* 14 (2004) 111–119;

Part III: The "Classic" Kerma Pottery from the Second Intermediate Period and the 18th Dynasty, in the present volume of *Ä&L*.

The statistics related to the ceramics from the late Hyksos Period and the New Kingdom (18th Dynasty) by shapes, fabrics and decoration are presented in the Tables and Graphs Nos. 5 and 6, respectively.

Eighty-nine is the total amount of Kerma sherds. Only five come from contexts of the Second Intermediate Period. The number of sherds suddenly increases during the 18th Dynasty, at the beginning of this period and especially during the reign of Thutmose III (strata d and c), amounting to eighty-four fragments. As mentioned above, the Kerma ceramics found in contexts from the late 18th Dynasty onwards must be considered residual material.⁴³

⁴² On the stratigraphy of 'Ezbet Helmi, M. BIETAK and I. FORSTNER-MÜLLER, *Ausgrabung eines Palastbezirkes der Tuthmosidenzeit bei 'Ezbet Helmi/Tell el-Dab'a*, Vor-

bericht für Herbst 2004 and Frühjahr 2005, *Ä&L* 15, 65–100, especially the table in p. 68.

Stratum (Ezbet Helmi)	Phase (Tell el-Dab'a)	Egyptian chronology
stratum g stratum f stratum e/2	Phase D/2	Late Hyksos Period
stratum e/1.2 stratum e/1.1	Phase D/1.2 Phase D/1.1	Early 18 th Dynasty
stratum d stratum c	Phase C/3 Phase C/2	Early–middle 18 th Dynasty (Thutmose III, 1478–1425 BC)
stratum b/3	Phase C/1	Amenophis III and Amarna period
stratum b/2	Phase B/3	Late 18 th Dynasty (Tutankhamun and Horemheb)
stratum b/1	Phase B/2	Ramesside Period

Table 1

Stratum	Amount of sherds	%	Inv. No.	Typology	Part preserved	Fabric	Ware	Decoration	Kerma chron.	Field reference	Publication
g = Phase D/2	1	20									
			8908D	cooking pot	body sherd	Nile E3	RPSP	incised	Middle Kerma	H/III-u/16, L1278	Part II, No. 16
f = Phase D/2	1	20									
			9071W	beaker	body sherd	Nile B2	[RP]S P	black-topped	Classic Kerma	H/VI-w/16, L4783	Part III, No. 1
e/2 = Phase D/2	3	60									
			8442N	cooking pot	body sherd	Nile E3	RPSP	incised	Classic Kerma	H/III-s/18, L0047	Part II, No. 17
			8964J	cooking pot	complete	Nile E1	TGSP	incised	Classic Kerma	H/VI-w-x/18, L5018	Part II, No. 15
			9071K	beaker	body sherd	Nile B2	RPSP	black-topped	Classic Kerma	H/VI-x/18, L5028	Part III, No. 2
Late Hyksos Period: 5 sherds											

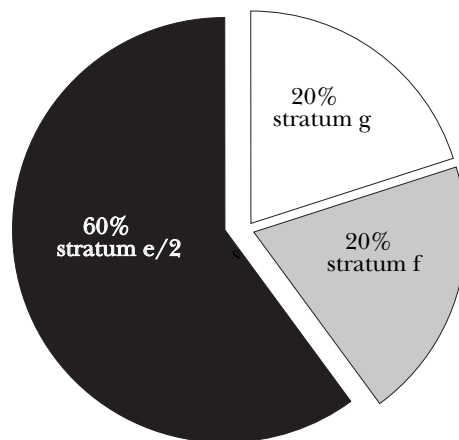

Table 2

Stratum	Amount of sherds	%	Inv. No.	Typology	Part preserved	Fabric	Ware	Deco-ration	Kerma Chron.	Field reference	Publication
e/1 = Phase D/1	5	7,25	8955R	beaker	body sherd	Nile B2	RPSP	black-topped	Classic Kerma	H/VI-x/19, L4929	Part I, No. 35
			9071O	beaker	body sherd	Nile B2	RPSP	black-topped	Classic Kerma	H/III-o/14, L2173	Part III, No. 3
			9071A	beaker	body sherd	Nile B2	RPSP	black-topped	Classic Kerma	H/VI-x/19, L4973	Part III, No. 4
			9071Y	beaker	body sherd	Nile B2	RPSP	black-topped	Classic Kerma	H/VI, x/19, L4975	Part III, No. 5
			9071Q	bowl	body sherd	Nile B2	RPSP	black-topped	Classic Kerma	H/VI-y/18, L4999	Part III, No. 6
e/1-d = Phase D/1-C/3	2	2,89	9080Q	bowl	body sherd	Nile B2	RPSP	black-topped	Classic Kerma	H/III-n/16, L2169	Part. III, No. 7
			9071H	cooking pot	rim sherd	Nile B2 s.	TG	incised	Classic Kerma	H/VI-t/19, L4126	Part. III, No. 8
d = Phase C/3	27	39,13	8205N	cooking pot	body sherd	Nile E3	TGSP	incised	Classic Kerma	H/III-q/18, E sect.	Part II, No. 13
			8929L1-2	bowl	rim and body sherds	Nile E1	TGSP	black-topped	Classic Kerma	H/VI-h/18, L3004V	Part I, No. 11
			8929M	cooking pot	rim sherd	Nile E3	PSP	incised	Classic Kerma	H/VI-h/18, L3003V	Part II, No. 12
			8932J	cooking pot	body sherd	Nile E3	TGSP	impressed	Classic Kerma	H/VI-u/12, L4107A	Part I, No. 23
			8937A	beaker	body sherd	Nile B2	RPSP	black-topped	Classic Kerma	H/VI-u/12, M1232	Part I, No. 9
			8938A	bowl?	body sherd	Nile B2	RPSP	black-topped	Classic Kerma	H/VI-u/12, L4107A	Part I, No. 14
			8938B1-2	beaker	body sherds	Nile B2	RPSP	black-topped	Classic Kerma	H/VI-u/12, L4107A	Part I, No. 4
			8938C	bowl	body sherd	Nile E1	[P]SP	black-topped	Classic Kerma	H/VI-u/12, L4107A	Part I, No. 18
			8942E	bowl	rim sherd	Nile E1	TGSP	black-topped	Classic Kerma	H/VI-u/12, L4107A	Part I, No. 12
			8942F	cooking pot	body sherd	Nile E3	TG	impressed	Classic Kerma	H/VI-u/12, L4107A	Part I, No. 25
			8942K	bowl	body sherd	Nile E1	TGSP	black-topped	Classic Kerma	H/VI-u/12, L4107A	Part I, No. 16
			8942L	cooking pot	body sherd	Nile E3	TG	impressed	Classic Kerma	H/VI-u/12, L4107A	Part I, No. 24
			8943M	beaker	rim sherd	Nile B2	[RP]SP	black-topped	Classic Kerma	H/VI-t/13, L4107	Part I, No. 1
			8954Z	bowl	body sherd	Nile B2	RPSP	black-topped	Classic Kerma	H/VI-x/19, L4919	Part II, No. 6
			8955F	beaker	body sherd	Nile B2	RPSP	black-topped	Classic Kerma	H/VI-x/19, L4919	Part II, No. 1
			8956L	beaker	base	Nile B2	RPSP	black-topped	Classic Kerma	H/VI-w/19, L4825	Part I, No. 32
			8964O	cooking pot	body sherd	Nile E1	RP	red polished	Classic Kerma	H/VI-t/12, L4099	Part II, No. 10
			8966T	bowl	rim sherd	Nile B2	SP	black-topped	Classic Kerma	H/VI-t/12, L4099	Part II, No. 5
			9071G	cooking pot	rim sherd	Nile E3	TGSP	incised	Classic Kerma	H/III-t/17, L1058	Part III, No. 17
			9072D	cooking pot	body sherd	Nile E1	TGSP	incised	Classic Kerma	H/VI-x/18, L4839	Part III, No. 16
			9072Z	bowl	body sherd	Nile B2	RPSP	black-topped	Classic Kerma	H/VI-t/13, L4043	Part III, No. 10
			9078W	bowl	body sherd	Nile B2	TGSP	impressed	Classic Kerma	H/VI-m/19, L6051	Part III, No. 13
			9079A	bowl	body sherd	Nile B2	TGSP	impressed	Classic Kerma	H/VI-w/16, L4604	Part III, No. 14
			9079B	beaker	body sherd	Nile B2	SP	black-topped	Classic Kerma	H/VI-w/16, L4604	Part III, No. 9
			9079X	cooking pot	body sherd	Nile B2 s.	TGSP	incised	Classic Kerma	H/III-n/14, L2125	Part III, No. 15
			9242J	bowl	body sherd	Nile C1	TGSP	incised	Classic Kerma	H/VI-m/19, L6051	Part III, No. 12
			9242M	bowl	body sherd	Nile B2	RPTG	black-topped	Classic Kerma	H/VI-m/20, L6051	Part III, No. 11

Table 3

Stratum	Amount of sherds	%	Inv. No.	Typology	Part preserved	Fabric	Ware	Deco-ration	Kerma chron.	Kerma Chron.	Field reference	Publication	
	8	12											
d-c = Phase C/3-C/2			8962M	beaker	body sherd	Nile B2	RPSP	black-topped	K. Classique	Classic Kerma	H/VI-w/12, L4018	Part II, No. 2	
			8966Z	bowl	body sherd	Nile B2	RPP	black-topped	K. Classique	Classic Kerma	H/VI-t/13, L4023	Part II, No. 7	
			8971V	bowl	rim sherd	Nile B2	RPSP	black-topped		Classic Kerma	H/VI-v/19, L4018	Part II, No. 4	
			9078X	bowl	body sherd	Nile C1/C2	TG	impressed		Classic Kerma	H/VI-t/13, L4053	Part III, No. 21	
			9078Y	bowl	body sherd	Nile B2	RPSP	black-topped		Classic Kerma	H/VI-t/13, L4053	Part III, No. 20	
			9080N	cooking pot	body sherd	Nile E1	TGSP	incised		Classic Kerma	H/III-o/13, M2005	Part III, No. 22	
			9160T	bowl	body sherd	Nile B2	RPSP	black-topped		Classic Kerma	H/VI-q/14, L6345	Part III, No. 18	
			9160U	bowl	body sherd	Nile C1	SP	black-topped		Classic Kerma	H/III-t/18, L1002	Part III, No. 19	
c = Phase C/2	27	39,13	8932D	bowl	rim sherd	Nile B2	TGSP	black-topped		Classic Kerma	H/VI-v/14, L4202	Part I, No. 13	
			8942M	cooking pot	body sherd	Nile E3	TG	impressed		Classic Kerma	H/VI-u/13, L4001	Part I, No. 28	
			8942N1-2	cooking pot	body sherds	Nile E3	TG	smoothed		Classic Kerma	H/VI-u/13, L4001	Part I, No. 30	
			8942O	cooking pot	body sherd	Nile E3	TGSP	impressed		Classic Kerma	H/VI-u/13, L.4001	Part I, No. 26	
			8943K	beaker	body sherd	Nile B2	RPSP	black-topped	K. Classique	Classic Kerma	H/VI-u/12, L4041	Part I, No. 2	
			8943L	beaker	body sherd	Nile B2	RPSP	black-topped	K. Classique	Classic Kerma	H/VI-t/13, L4021	Part I, No. 3	
			8943N	bowl	body sherd	Nile E1	RP	black-topped		Classic Kerma	H/VI-t/13, L4021	Part I, No. 17	
			8943O	bowl	body sherd	Nile E1	[P]	black-topped		Classic Kerma	H/VI-t/13, L4023	Part I, No. 19	
			8943P1-2	cooking pot	body sherds	Nile E1	TGSP	impressed		Classic Kerma	H/VI-t/13, L4026	Part I, No. 21	
			8943Q	cooking pot	body sherd	Nile E3	TGSP	impressed		Classic Kerma	H/VI-t/13, L4001V	Part I, No. 27	
			8943R	cooking pot	body sherd	Nile E3	PSP	black-topped?		Classic Kerma	H/VI-u/13, L4001V	Part I, No. 29	
			8943S	cooking pot	body sherd	Nile E3	TGSP	impressed		Classic Kerma	H/VI-u/13, L.4001V	Part I, No. 22	
			8943T	bowl	body sherd	Nile E1	RP	black-topped		Classic Kerma	H/VI-u/13, L.4001V	Part I, No. 15	
			8956M	beaker	body sherd	Nile B2	RPSP	black-topped		Classic Kerma	H/VI-v/16, L4001V	Part I, No. 33	
			8956N	beaker	body sherd	Nile B2	RPSP	black-topped		Classic Kerma	H/VI-v/17, L4551	Part I, No. 34	
			8962Q	bowl?	body sherd	Nile B2	RPSP	black-topped		Classic Kerma	H/VI-t/11, L4238	Part II, No. 8	
			9071M	beaker	body sherd	Nile B2	RPSP	black-topped		Classic Kerma	H/III-p/16, L2017	Part III, No. 26	
			9071P	beaker	body sherd	Nile B2	RPSP	black-topped		Classic Kerma	H/III-o-/16, L2017	Part III, No. 27	
			9075U	cooking pot	body sherd	Nile B2 s.	RPS	red polished		Classic Kerma	H/VI-v/17, M1201	Part III, No. 29	
			9075V	cooking pot	body sherd	Nile B2 s.	RPS	red polished		Classic Kerma	H/VI-v/15, M1201A	Part III, No. 30	
			9075W1-2	bowl	body sherd	Nile C2	RSP	black-topped		Classic Kerma	H/VI-v/17, M1201	Part III, No. 28	
			9075X	cooking pot	body sherd	Nile B2 s.	TG	impressed		Classic Kerma	H/VI-v/17, M1201	Part III, No. 31	
			9075Y	beaker	body sherd	Nile B2	RPSP	black-topped		Classic Kerma	H/VI-v/17, M1201	Part III, No. 23	
			9075Z	beaker	body sherd	Nile B2	RPSP	black-topped		Classic Kerma	H/VI-t/16-17, L6024	Part III, No. 24	
			9079C	beaker	body sherd	Nile B2	SP	black-topped		Classic Kerma	H/VI-v/16, M1203	Part III, No. 25	
			9080E	cooking pot	body sherd	Nile B2 s.	TG	impressed		Classic Kerma	H/III-p/16, L2017	Part III, No. 32	
			9080F	cooking pot	body sherd	Nile B2 s.	TGSP	impressed		Classic Kerma	H/III-p/16, L2017	Part III, No. 33	
	Early and early-middle 18th Dynasty: 69 sherds												

Table 3 continued

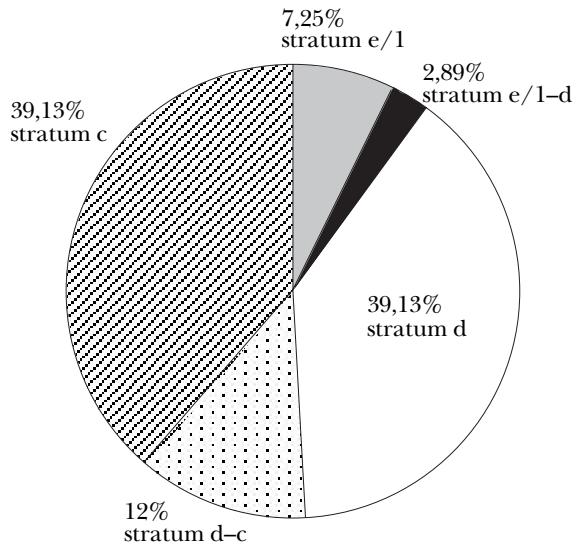

Graph for Table 3

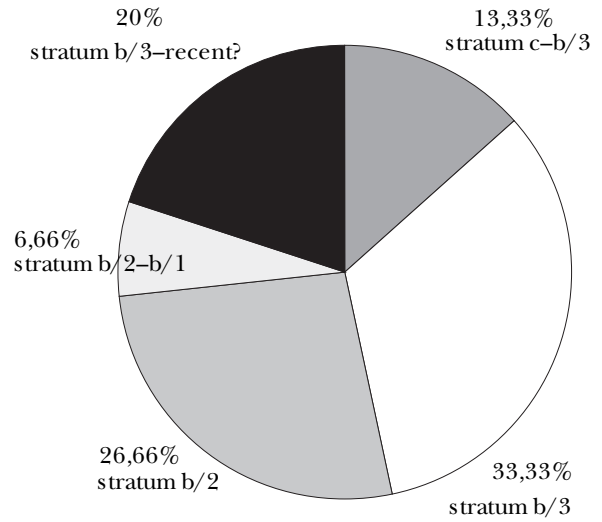

Graph for Table 4

Stratum	Amount of sherds	%	Inv. No.	Typology	Part preserved	Fabric	Ware	Decoration	Kerma chron.	Field reference	Publication
c-b/3 = Phase C/2-C/1	2	13,33									
			8956O	bowl	body sherd	Nile B2	RPS	black-topped	Classic Kerma	H/VI-v/19, L4878	Part I, No. 36
			8962S	beaker	body sherd	Nile B2	RPSP	black-topped	Classic Kerma	H/VI-w/19, L4825	Part II, No. 3
b/3 =Phase C/1	5	33,33									
			8442L	cooking pot	body sherd	Nile E3	PSP	polished	Classic Kerma	H/III-r/19, L-	Part II, No. 11
			8892E	cooking pot	body sherd	Nile E3	TGSP	incised	Middle Kerma	H/III-q/19, L0007	Part II, No. 14
			8930D	beaker	body sherd	Nile B2	RPSP	black-topped	Classic Kerma	H/VI-u/12, L4018	Part I, No. 6
			8930E	beaker	body sherd	Nile B2	RP?	black-topped	Classic Kerma	H/VI-u/12, L4018	Part I, No. 8
		8966U	cooking pot	body sherd	Nile E1	RP	red polished	Classic Kerma	H/VI-t/11, L4008	Part II, No. 9	
b/2 =Phase B/3	4	26,66									
			8441Z	cooking pot	rim sherd	Nile E3	TG	impressed	Middle Kerma	H/III-q/16, L-	Part I, No. 20
			8912W	beaker	rim sherd	Nile B2	[RP]SP	black-topped	Classic Kerma	H/VI-u/12, L4014	Part I, No. 5
			8930F	beaker	body sherd	Nile B2	RPSP	black-topped	Classic Kerma	H/VI-u/12, L4014	Part I, No. 7
		9075T	bowl?	body sherd	Nile C1 s.	TGSP	smoothed	Classic Kerma	H/VI-o/17, L4009	Part III, No. 34	
b/2-b/1 = Phase B/3-B/2	1	6,66									
			8442M	beaker	base fragment	Nile B2	RPSP	black-topped	Classic Kerma	H/III-r/19, L-	Part I, No. 10
b/3 to recent?	3	20									
			9070Z	cooking pot	rim sherd	Nile E1	RPP	black-topped	Classic Kerma	H/III-o/14, L2004	Part III, No. 36
			9071B	cooking pot	body sherd	Nile E3	TGSP	incised	Classic Kerma	H/III-o/14, L2001	Part III, No. 37
		9072H	beaker	body sherd	Nile B2	SP	black-topped	Classic Kerma	H/III-n/14, L2000	Part III, No. 35	
Late 18 th Dynasty to recent times?: 15 sherds											

Table 4

Period	Stratum and Phase	Amount of sherds	%
Second Int. Period	Late Hyksos Period (strata g to e/2 = Phase D/2)	5	5,61
New Kingdom*		84	94,39
18 th Dynasty	Early and early-middle 18 th Dynasty (strata e/1 to c = Phase D/1 to C/2): 69		
Late 18 th Dynasty onwards	Late 18 th Dyn. to recent times? (strata c-b/3; b/3 to recent times? = Phase C/3 to recent times?): 15		
Total amount of sherds		89	100,00

* The Kerma sherds from strata later than stratum c are considered residual material and included all together inside the 18th Dynasty for statistics

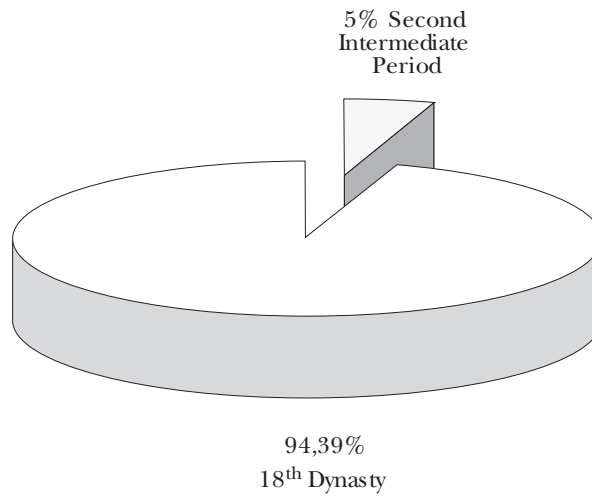
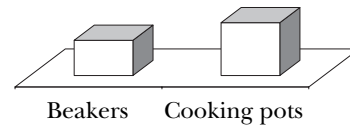
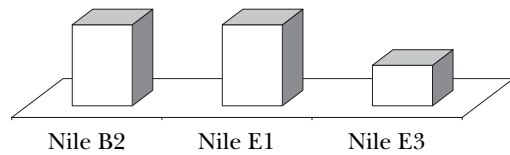

Table 5

Shape	Amount	%
Beakers	2	40
Cooking pots	3	60
Total	5	100



Fabric	Amount	%
Nile B2	2	40
Nile E1	2	40
Nile E3	1	20
Total	5	100



Decoration	Amount	%
Black-topped rim	2	40
Incised	3	60
Total	5	100

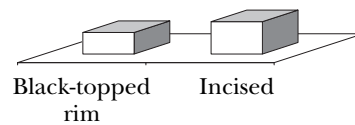
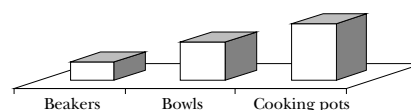
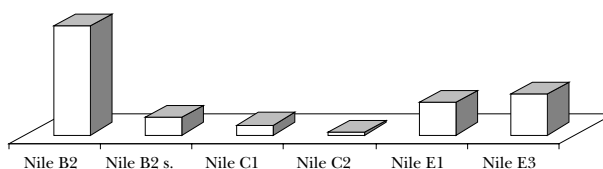

Table 6

Shape	Amount	%
Beakers	27	32,14
Bowls	28	33,34
Cooking pots	29	34,52
Total	84	100



Fabric	Amount	%
Nile B2	43	51,2
Nile B2 s.	7	8,33
Nile C1	4	4,76
Nile C2	1	1,2
Nile E1	13	15,47
Nile E3	16	19,04
Total	84	100



Decoration	Amount	%
Black-topped rim	52	61,9
Impressed	15	17,85
Incised	10	11,9
Undecorated (polished)	5	5,95
Undecorated (smoothed)	2	2,4
Total	84	100

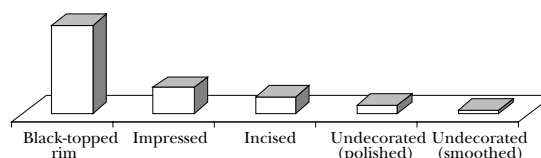

Table 7

II. Some corrections to the Kerma sherds published in *Ä&L* 12 and 14

a. The Kerma sherds Inv. Nos. 8908D⁴⁴ (found in a pottery context of stratum g = Phase D/2; late Hyksos Period), 8892E⁴⁵ (in stratum b/2 = Phase B/3, reign of Horemheb), and 8441Z⁴⁶ (in stratum a, renamed now b/2),⁴⁷ were classified by Charles Bonnet as “Middle Kerma”,⁴⁸ instead of “Classic Kerma” as it appeared in the

publication. These “Middle Kerma” sherds in contexts of the Second Intermediate Period and the New Kingdom must be considered residual material.

b. The fabric of the cooking pots Inv. Nos. 8966Z (*Ä&L* 14, 115, No. 7) and 8966U (*Ä&L* 14, 115, No. 9) is I-e-1 (Nile E₁) as it was mentioned in the title, instead of I-e-2 (Nile E₂) written inside the box of the vessel description. The fabric of the

⁴³ The sherds found in strata later than stratum c are included all together inside the 18th Dynasty for statistics.

⁴⁴ Published in *Ä&L* 14, 117 and fig. 3:e (No. 16).

⁴⁵ Published in *Ä&L* 14, 116 and fig. 3:c (No. 14).

⁴⁶ In *Ä&L* 12, 177 and fig. 3:a (No. 20).

⁴⁷ See *Ä&L* 14, 111, note 6 and the bibliography mentioned there.

⁴⁸ Personal communication. Tell el-Dab^a, April/2006.

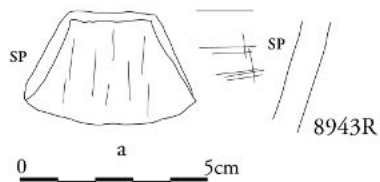

Fig. 6

cooking pot Inv. No. 8943P₁₋₂ (*Ä&L* 12, 177, *No. 21*) is I-e-1 (Nile E₁) as it was written inside the box, instead of Nile E₃ mentioned below.

The drawing and the photo of the cooking pot Inv. No. 8943R (*Ä&L* 12, 179, *No. 29*, fig. 3:j and plate 3:j) were omitted in the publication. The drawing is included here (Fig. 6:a).

Abbreviations:

f-mi	fine to medium quality of the groundmass
H ₁	total height of the vessel
Ha ₁	hand made shaping technique
I-b-2	Nile B ₂
I-c-1	Nile C ₁
I-c-2	Nile C ₂
I-e-1	Nile E ₁
I-e-3	Nile E ₃
Md	maximum diameter
m	fired in medium atmosphere
mi	medium quality of the groundmass
mi-r	medium to coarse quality of the groundmass

ox	fired in an oxidizing atmosphere
Rd	rim diameter
re	fired in controlled firing conditions
RPP	red-slipped polished exterior, polished interior
RPS	red-slipped polished exterior, black interior
RPSP	red-slipped polished exterior, black polished interior
RPTG	red-slipped polished exterior, uncoated interior
TG	uncoated
TGSP	uncoated exterior, black polished interior
Wd	wall thickness

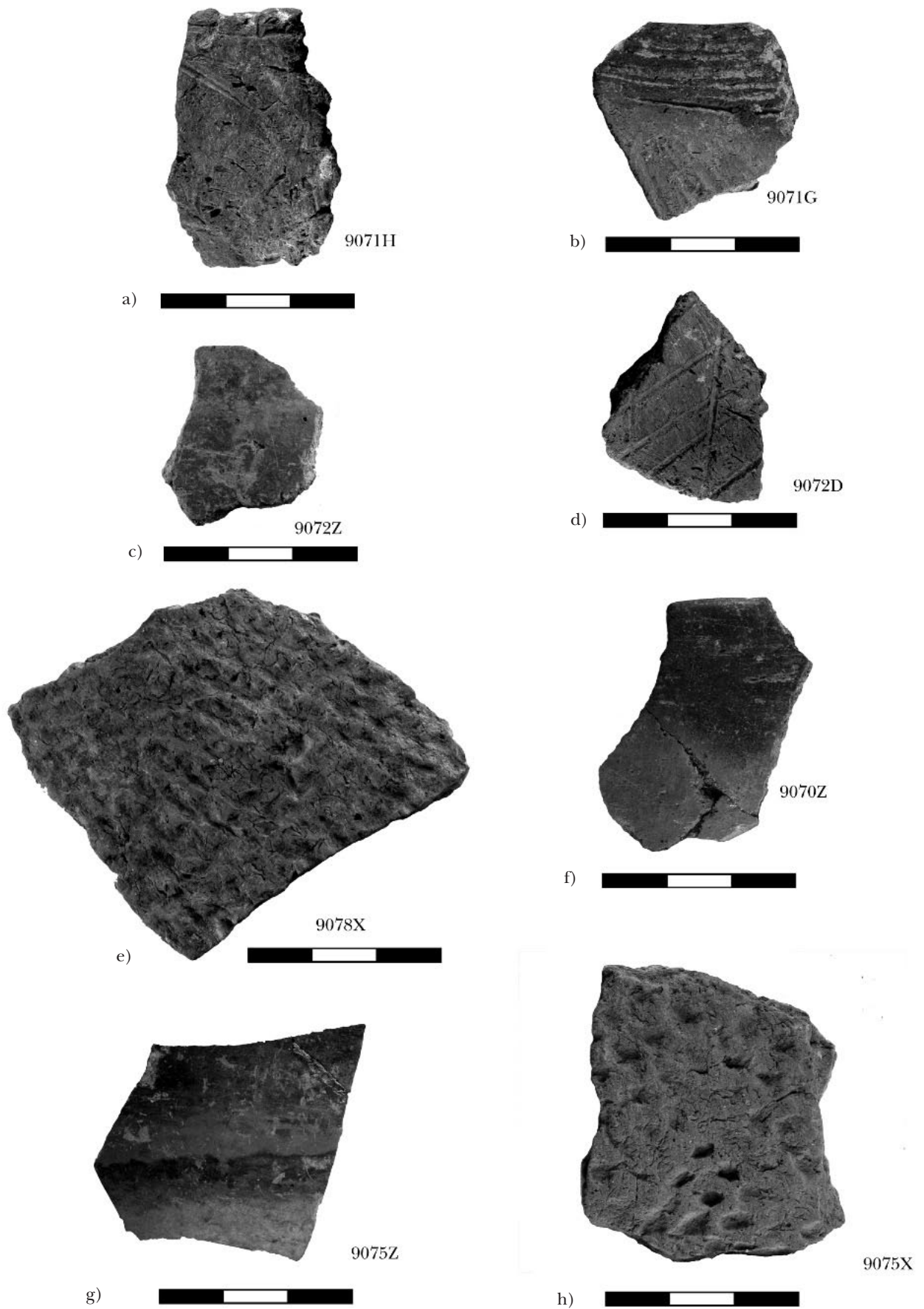

Plate 1

